

Fabrication of a CuO-infiltrated ZnO composite and its gas sensing properties

GAKUJI UOZUMI, MASARU MIYAYAMA

Research Center for Advanced Science and Technology, The University of Tokyo, 4-6-1, Komaba, Meguro-ku, Tokyo 153, Japan

HIROAKI YANAGIDA

Department of Applied Chemistry, Faculty of Engineering, The University of Tokyo, 7-3-1, Hongo, Bunkyo-ku, Tokyo 113, Japan

CuO–ZnO composites were fabricated by heating with infiltrating a cupric solution into a porous ZnO matrix. The composites possess a nonlinear, rectifying current–voltage character due to the presence of a p–n junction produced by the CuO and ZnO semiconductors. This junction is essential for the creation of voltage-dependent sensing properties of humidity and flammable gases. The forward current (CuO: positive bias) greatly increased with increasing the relative humidity, while the reverse current only slightly increased with an equivalent increase in the relative humidity. This asymmetric current change with the humidity is similar to that observed for conventional CuO and ZnO sintered specimens heterocontact produced by mechanically pressing the specimens together. The current was increased by the introduction of CO and H₂ (4000 p.p.m.) at 250 °C, with the current increase due to CO exceeding that of the H₂ in the measured bias region within ± 6 V. The utility of the new processing method for forming p–n semiconductor junctions open to the atmosphere has been shown.

1. Introduction

Various metal oxide based gas sensors have been developed, and in some cases noble metals have been added to the metal oxide to act as a catalyst and thereby improving gas sensitivity and selectivity [1]. There have been a considerable number of studies on the use of catalysts in gas sensors but only a few papers have reported work on the application of the interfacial properties of the metal oxides in chemical sensors. A heterocontact of p- and n-type semiconducting metal oxides, such as a CuO(p-type)/ZnO(n-type) heterocontact, is an example of a sensor using the interfacial properties [2, 3]. The heterocontact is made by physically pressing together the two sintered metal oxides. It shows a rectifying current (I)–voltage (V) characteristic similar to that of a point contact diode whose contacted point is exposed to the atmosphere. The adsorption and chemical reactions of gas species at the interface of a heterocontact produces changes in the rectifying I – V characteristics, and as a result, they can be detected as electric signals. Hence the CuO/ZnO heterocontact shows unique sensing properties, such as D.C. or A.C. voltage-dependent gas sensitivity for humidity and flammable gases, and a good CO selectivity [4, 5]. Since it is generally difficult for ordinary metal oxide gas sensors to distinguish CO from H₂, the CuO/ZnO heterocontact is of considerable interest as a sensor possessing novel sensing mechanisms [6, 7].

As previously mentioned, a CuO/ZnO heterocontact is made of two sintered metal oxides with their uneven surfaces pressed together using a mechanical press. However, the interfacial area is limited in such a structure, and the sensing properties are affected by the surface microstructure (roughness) and mechanical pressing conditions. An initial attempt to fabricate CuO–ZnO composites in order to obtain a stable heterocontact proved unsuccessful since the composites did not show a rectifying I – V character [8]. In the present study, CuO–ZnO composites with a large interfacial area were prepared by infiltrating the CuO phase into a continuous ZnO matrix with a large pore volume. The produced CuO–ZnO composite showed a rectifying I – V character which is essential for the required sensing properties. The sensing properties of the composite for detecting flammable gases and humidity were examined.

2. Experimental procedure

Fine powders of ZnO (purity 99.99%) and carbon particles with an average diameter of 100 μ m were mixed in the ratio 33:67 vol %. The mixed powder was pressed at 98 MPa and shaped into a rectangular bar of dimensions 15 \times 5 \times 5 mm, and sintered in air at 800 °C for 3 h. After sintering, open and large pores of approximately the same size with carbon particles

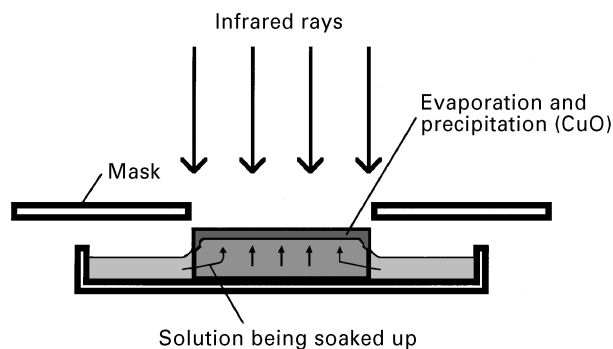

Figure 1 A Schematic diagram of the infiltration process.

remained in the ZnO matrix. The relative density of the ZnO matrix was about 40% of the theoretical value for ZnO. Cupric hydroxide was dissolved in 25% ammonia solution to form a 0.14M solution and NaOH solution was added to achieve a Na/Cu ratio of 0.02. The infiltration process is illustrated in Fig. 1. Five ml of the cupric hydroxide ammonia solution was put into a beaker, and the ZnO matrix was dipped into the cupric solution. The top surface of the ZnO matrix was heated up to approximately 100 °C by an infrared-ray lamp using an Al plate mask. Using differential thermal analysis (DTA) the cupric hydroxide solution was shown to change mostly into CuO at about 92–100 °C and change completely below 150 °C. Accordingly, in our process, the evaporation of the solution and the precipitation of CuO occur simultaneously in the heated part of the ZnO matrix. The infrared heat treatment was continued until the cupric solution in the beaker was completely evaporated, and this infiltration process was repeated 3 times. Since the top surface of the ZnO matrix was not completely covered by the CuO a CuO powder paste, obtained by heating the cupric solution, was coated onto the top surface of the ZnO matrix. After CuO-coating, the composite was fired in air at 400 °C for 1 h. The crystalline phases in the sample were examined using X-ray diffraction (XRD) techniques, and the microstructures were examined with a scanning electron microscope (SEM).

As is shown in Fig. 2, an In–Ga alloy was applied to the ZnO side (bottom surface of the ZnO matrix), and a Pt plate was directly attached to the CuO side (top

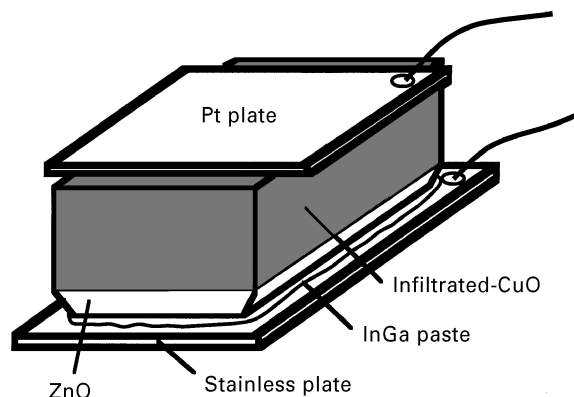

Figure 2 A schematic diagram of the CuO-infiltrated ZnO.

surface of the ZnO matrix) as ohmic electrodes. The edge at the ZnO side was polished by emery paper to prevent a leakage current between the electrodes through the CuO phase. The sample was set in a temperature-controlled chamber with a volume of 480 cm³, and connected to a programmable electrometer (Advantest R8340A) which had a constant voltage supply. The electrical measurements were conducted in various relative humidities (5–50%) at 18 °C, and in CO (4000 p.p.m.) and H₂ (4000 p.p.m.) balanced with air at 250 °C. The humidity was changed by controlling the flow rates of dry air and wet air saturated with water vapour. In all the measurements the total gas flow rate was kept constant at 300 ml min⁻¹.

3. Results and discussion

3.1. Structure of the CuO–ZnO composite gas sensor

In the XRD patterns of the composite shown in Fig. 3, only peaks that could be assigned to ZnO and CuO were observed and there was no evidence for any reaction product phase. Fig. 4(a–d) shows SEM photographs of the CuO-infiltrated ZnO. Fig. 4a shows the CuO film on the top surface of the composite whilst Fig. 4b shows the top surface after removal of the CuO film. The CuO film on the top surface (Fig. 4a) has some cracks, but there are no large holes. Under the top CuO film, CuO particles with a diameter of about 10–70 μm are observed in the large pores of the ZnO matrix as is shown in Fig. 4b. Fig. 4c shows the side surface of the composite which is partially covered with a CuO film. From the cross-section of the composite shown in Fig. 4d the thickness of the CuO film was estimated to be approximately 40 μm, and most of CuO particles are distributed to a depth of about 0.3 mm. It was found from these photographs that most of the CuO particles are contacted with one another to form a continuous CuO phase with the surface CuO film.

The weight of the infiltrated CuO phase was estimated from the weight change during the infiltration process to be 0.015 g in the ZnO matrix of 0.5 g. Assuming that the CuO phase is solely composed of the CuO film, the relative density of the CuO phase can be estimated from the film-covered area and the film thickness ($\approx 40 \mu\text{m}$) to be about 30% of the theoretical value. Since the CuO phase is actually

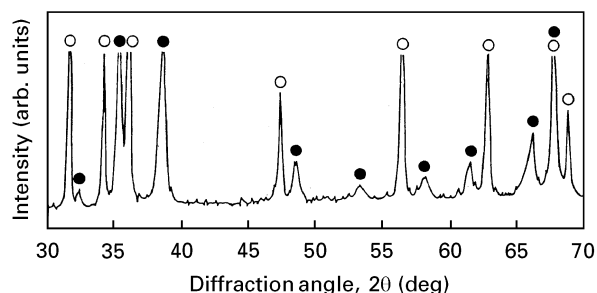

Figure 3 XRD patterns of a CuO-infiltrated ZnO composite after firing at 400 °C. Key: (●) CuO and (○) ZnO.

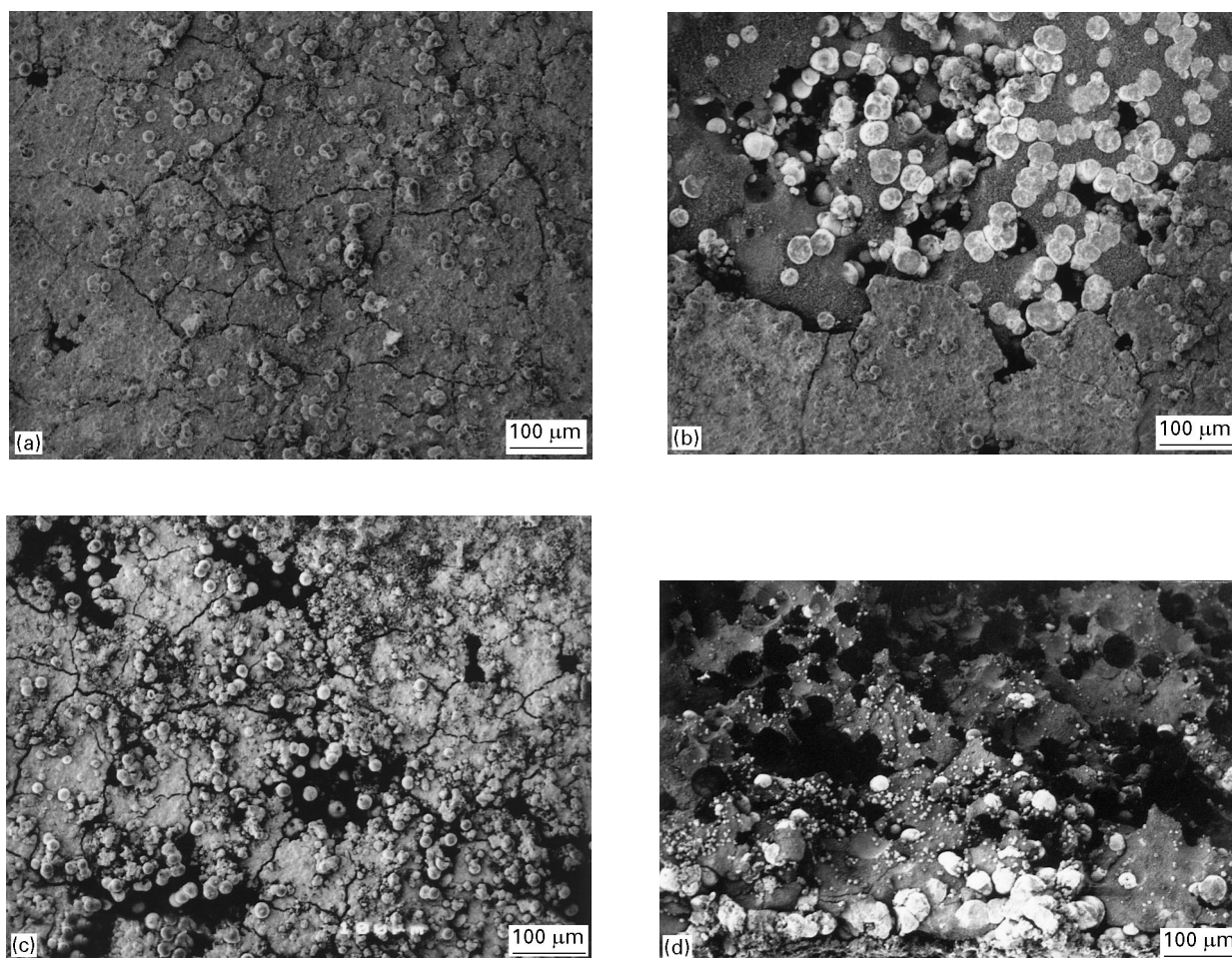

Figure 4 (a) Surface of the composite (top CuO film), (b) surface of the composite (beneath the CuO film), (c) surface of the composite (side CuO film), and (d) cross-section of the composite.

composed of CuO particles in the matrix and also the surface CuO film, the average relative density of the CuO phase is expected to be lower than 30%. In fact, the CuO particles are made of sparse CuO flakes, as shown in Fig. 5.

Even though the side surface is only partially covered with a CuO film, there is continuity of the CuO film, which was confirmed at the electroding stage. Before polishing the edge of the ZnO matrix, the resistivity of the CuO-infiltrated ZnO sample was two orders of magnitude lower than that of the ZnO matrix and the I - V characteristic was linear. After polishing the edge of the ZnO matrix as shown in Fig. 2, the resistivity of the sample increased one order of magnitude and the rectifying I - V characteristic was observed. This result indicates that the side CuO film is electrically continuous and its resistivity is lower than that of the matrix, and thus the current is assumed to flow across the CuO/ZnO interface after polishing of the edge.

It can be concluded from the above results that a p-n interface was formed between a continuous CuO phase and the ZnO matrix. Since the resistivity of the ZnO matrix is much larger than that of the CuO phase, the resistivity of the composite is dominated by those of the CuO/ZnO interfaces and ZnO matrix. Fig. 6 shows a schematic view of the infiltrated CuO phase in the composite. Due to three-dimensional contacts between the CuO phase and the ZnO matrix,

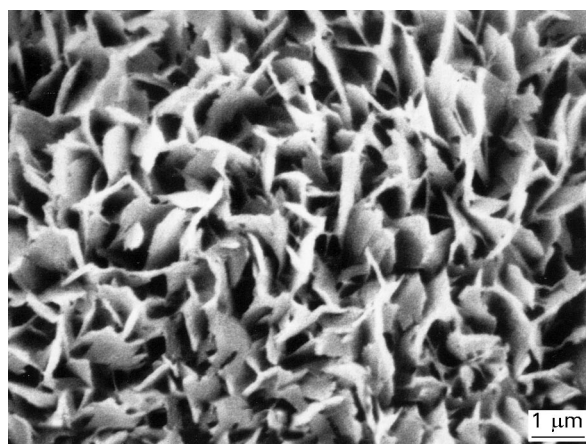

Figure 5 SEM photograph of the CuO particle surface.

the heterocontact area in this composite is expected to be larger than that of the conventional CuO/ZnO heterocontact made by physically pressing together two sintered metal oxides. Although the matrix was covered with a CuO film, the reducing gases can diffuse into the matrix, because there are several holes in the side CuO film.

3.2. Humidity sensing properties of the CuO-ZnO composite

Fig. 7 shows current(I)-voltage(V) curves for the CuO-ZnO composite in various humid atmospheres

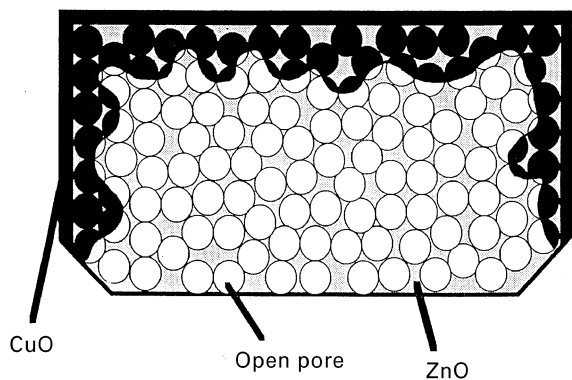

Figure 6 Schematic view of the infiltrated CuO phase.

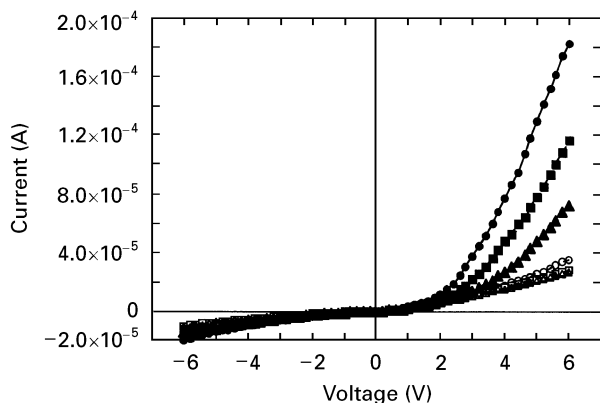

Figure 7 I - V curves for the CuO-ZnO composite at relative humidities of (●) 51%, (■) 41%, (▲) 31%, (○) 20%, (□) 11% and (△) 5%.

at 18 °C. A sharp increase in the forward current (CuO side: + bias, ZnO side: - bias) was observed when the relative humidity was increased. The forward current measured at + 6 V bias increased 8 times with an increase in the relative humidity from 5–51%, while the reverse current measured at - 6 V bias increased by a factor of two. Thus a humidity-dependent rectifying I - V characteristic was observed. The bias-dependent current increase in the composite is the same as that observed in conventional heterocontacts made by mechanically pressing together two sintered metal oxides [5]. The humidity sensing properties of the ZnO matrix itself were also measured. As is shown in Fig. 8, no nonlinear I - V rectifying characteristics were observed, and the measured current increase was only 10% for a change in humidity from 5%–51%. Accordingly, the humidity sensing properties of the composite are attributed to the CuO/ZnO interface formed within the CuO-ZnO composite structure that is open to the atmosphere.

In this composite, the forward current at a bias higher than a critical value increases remarkably with increasing humidity. Fig. 9 shows the dependence of the forward current on the relative humidity at various values of the forward bias. When the forward bias is higher than 3 V, there is a large increase in the current at relative humidities higher than 20%. On the other hand, when the forward bias is lower than 3 V, the humidity dependence of the current is small. In the case of the CuO/ZnO heterocontact, the humidity

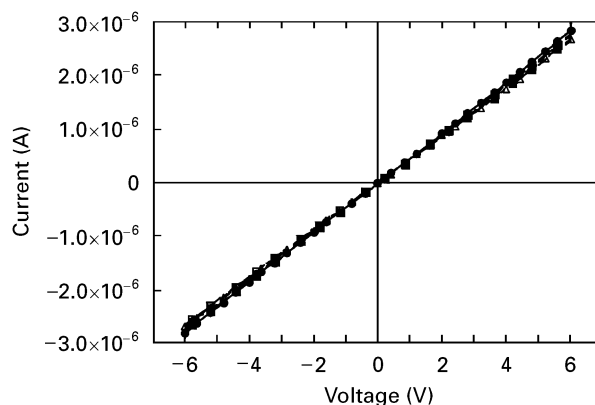

Figure 8 I - V curves for the of ZnO matrix at relative humidities of (●) 51%, (■) 41%, (▲) 31%, (○) 20%, (□) 11% and (△) 5%.

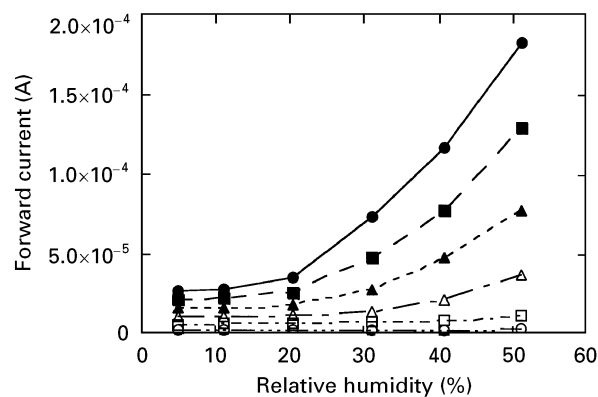

Figure 9 Dependences of forward current on relative humidity at forward bias values of: (●) 6V, (■) 5V, (▲) 4V, (△) 3V, (□) 2V and (○) 1V.

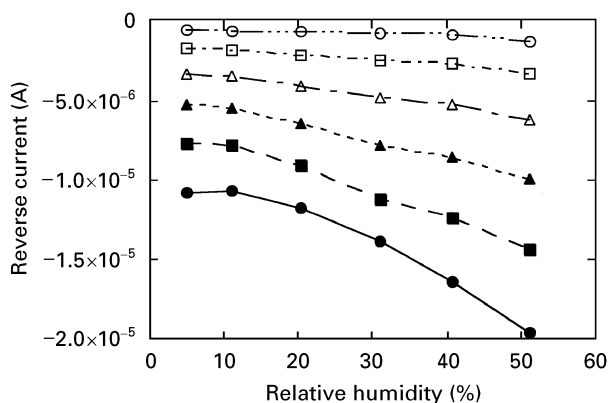

Figure 10 The dependence of the reverse current on the relative humidity at reverse bias values of: (●) - 6V, (■) - 5V, (▲) - 4V, (△) - 3V, (□) - 2V and (○) - 1V.

sensitivity is also dependent on the forward bias, and a significant increase in the forward current is observed at values of the bias between + 0.8– + 1.0 V [5]. Fig. 10 shows the dependence of the reverse current of the composite on the relative humidity at various values of the reverse bias. Contrary to the case of the forward current, the ratio of the currents measured at humidities of 51 and 5% was within two and with the trend in the humidity dependence being independent of the reverse bias.

This current increase in the heterocontacts can be explained in terms of the following mechanisms. The physisorbed water saturates the interface states, which leads to the release of trapped electrons which in turn results in a decrease of the barrier height. Thus the current flow through the CuO/ZnO interface increases as in the ideal p-n junction [9]. Furthermore, the electrolysis of physisorbed water can occur at the CuO/ZnO interface by the application of a forward bias at a high relative humidity. In the electrolysis, mobile protons are produced which increases the forward current [5].

At low relative humidities ($\leq 20\%$), there is a linear relationship between the natural logarithm of the current ($\ln I$) and voltage (V) under the forward bias, as is shown in Fig. 11. In an ideal p-n junction, the relationship between the forward current (I_f) and voltage (V) can be expressed as:

$$I_f \propto \exp(qV/\eta kT) \quad (1)$$

where V is the voltage applied to the p-n junction, η is the diode factor which depends on the ratio of the drift current and diffusion current of the junction current, and the value of η ranges from 1 to 2 [10]. In Fig. 11, almost linear relations are observed under forward bias values higher than +2.5 V, however, the value of η obtained from the slope of the $\ln I$ - V curve was about 116. The value of η is much larger than that of an ideal p-n junction.

In the case of the composite, the required bias to increase the forward current was approximately three times larger than that in the CuO/ZnO heterocontact. This can be explained by the point that only a portion of the D.C. bias applied to the CuO-ZnO composite is applied to the CuO/ZnO interface. As previously mentioned, the resistivity of the composite is determined by those of ZnO matrix and CuO/ZnO interface. Thus, it is considered that a portion of the d.c. bias is attributed to the ZnO phase. In the case of a relatively ideal CuO and ZnO junction made by the sputtering method, the relationship between $\ln I$ and V has been reported to be almost linear under forward bias values higher than +0.8 V [11]. The linear relationship observed above 2.5 V in the CuO-ZnO composite leads to the assumption that approximately one-third of the total d.c. bias applied to the composite reached the CuO/ZnO interface. This assumption is consistent with the fact that the required bias to increase the forward current at high humidity values is three times larger than that of the CuO/ZnO heterocontact.

For very large η values, the p-n junction in the composite can be considered to be far from the condition of lattice matching. Even in the relatively ideal CuO/ZnO junction made by sputtering, the η value was about 16 [11]. Accordingly, the charge transport mechanism in the composite can not be explained by the ideal model, but instead it appears to be governed by the interface states. The tunnelling or recombination through the interface states plays a dominant role in the charge transfer. This is because the CuO phase in this study has numerous lattice defects and surface adsorbates due to the low-temperature firing conditions and porous microstructure.

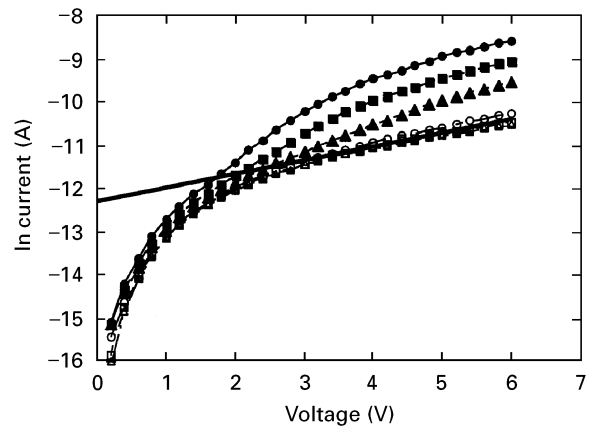

Figure 11 Natural logarithm of current as a function of forward bias at relative humidities of: (●) 51%, (■) 41%, (▲) 31%, (○) 20%, (□) 10% and (△) 5%.

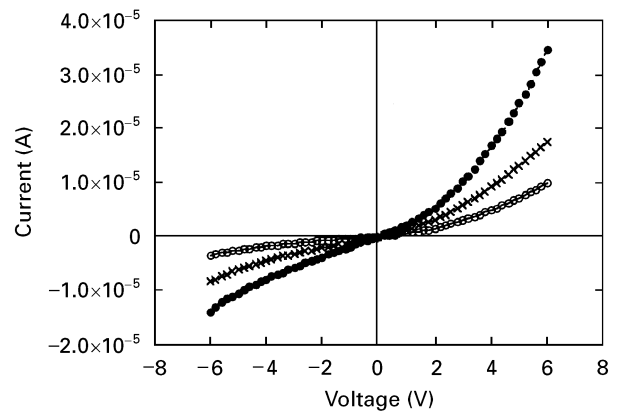

Figure 12 I-V curves of CuO-ZnO composite in (○) air, (●) 4000 p.p.m. CO, and (×) 4000 p.p.m. H₂ at 250 °C.

3.3. Gas sensing properties of the CuO-ZnO composite

Fig. 12 shows the current changes created by the introduction of CO or H₂ (4000 p.p.m.) at 250 °C. The observed current increase for CO was much larger than that for H₂ in the measured bias region within ± 6 V, i.e., the sensitivity for CO exceeded that for H₂. Under the same conditions, the I-V relations for the pure ZnO matrix were linear with the current increases being only 16 and 30% of the current in air for the CO and H₂ gases, respectively. Accordingly, if the oxidation reaction of the reducing gases on the ZnO surface is the dominant factor that determines the current flow, then the marked sensitivity for CO of the composite can not be explained. Although the rectifying I-V character of the CuO-ZnO composite was not as sharp as that of the CuO/ZnO heterocontact, the large sensitivity and CO selectivity of the composite are considered to be induced by the interaction between the CuO/ZnO interface and CO, as previously discussed in the case of the CuO/ZnO heterocontact [12].

The sensitivity and selectivity of the composite gas sensor in the present study are at the same level with those of CuO/ZnO heterocontact gas sensors. However, a higher sensitivity, and better CO selectivity with good reproducibility could be obtained if the

microstructures of the ZnO matrix and infiltrated CuO could be controlled.

4. Conclusions

Composites consisting of a continuous CuO phase in a ZnO matrix were fabricated using an infiltration process. The composites showed rectifying I - V characteristics. The currents significantly increased in response to an increase in the relative humidity from 5–51% at 18°C and by the introduction of CO or H₂ at 250°C. It has been suggested that the composites have p-n interfaces exposed to the atmosphere, that produce the voltage-dependent gas sensing properties.

References

1. D. KOHL, *Sensors and Actuators B1* (1990) 158.
2. Y. NAKAMURA, A. ANDO, T. TSURUTANI, O. OKADA, M. MIYAYAMA, K. KOUmoto and H. YANAGIDA, *Chem. Lett.* (1986) 413.
3. Y. NAKAMURA, T. TSURUTANI, M. MIYAYAMA, O. OKADA, K. KOUmoto and H. YANAGIDA, *J. Chem. Soc. Jpn* (1987) 477

4. K. HIKITA, M. MIYAYAMA and H. YANAGIDA, *J. Ceram. Soc. Jpn* **102** (1994) 810.
5. Y. NAKAMURA, M. IKEJIRI, M. MIYAYAMA, K. KOUmoto and H. YANAGIDA, *J. Chem. Soc. Jpn* **6** (1985) 1154.
6. K. K. BAEK and H. L. TULLER, *Solid State Ionics* **75** (1995) 179.
7. S. T. JUN and G. M. CHOI, *Sensors and Actuators B* **17** (1994) 175.
8. B. C. SHIN, M. MIYAYAMA and H. YANAGIDA, *J. Mater. Sci. Lett.* **13** (1994) 719.
9. E. TRAVERSA, A. BIANCO, G. MONTESPERELLI, G. GUSMANO, A. BEARZOTTI, M. MIYAYAMA and H. YANAGIDA, *Ceram. Trans.* **43** (1994) 375.
10. S. M. SZE, "Physics of semiconductor devices," 2nd. Edn. (Wiley, New York, 1981) p. 92.
11. Y. USHIO, M. MIYAYAMA and H. YANAGIDA, *Sensors and Actuators B* **12** (1993) 135.
12. Y. NAKAMURA, H. YOSHIOKA, M. MIYAYAMA and H. YANAGIDA, *J. Electrochem. Soc.* **137** (1990) 940.

*Received 6 February
and accepted 19 December 1996*